



LIGHTING AND SIGNS



## FOUNDATION LIGHTING AND SIGNS SYSTEM SECTION 10

### CONTENTS

INTRODUCTION .....	10-3
PRODUCT BENEFITS .....	10-3
RECOMMENDED FACTORS of SAFETY for DESIGN .....	10-4
DESIGN GUIDELINES.....	10-5
LIGHT POLE STANDARDS SUPPORTS .....	10-6
LATERALLY LOADED FOUNDATIONS.....	10-8
PRODUCT SPECIFICATIONS.....	10-10

### SYMBOLS USED IN THIS SECTION

FS .....	Factor of Safety	10-4
AASHTO.....	American Association of State Highway and Transportation Officials	10-6
EPA .....	Effective Projected Area	10-6

#### DISCLAIMER

The information in this manual is provided as a guide to assist you with your design and in writing your own specifications.

Installation conditions, including soil and structure conditions, vary widely from location to location and from point to point on a site.

Independent engineering analysis and consulting state and local building codes and authorities should be conducted prior to any installation to ascertain and verify compliance to relevant rules, regulations and requirements.

Hubbell Power Systems, Inc., shall not be responsible for, or liable to you and/or your customers for the adoption, revision, implementation, use or misuse of this information. Hubbell, Inc., takes great pride and has every confidence in its network of installing contractors and dealers.

Hubbell Power Systems, Inc., does NOT warrant the work of its dealers/installing contractors in the installation of CHANCE® Civil Construction foundation support products.

## INTRODUCTION

Hubbell Power Systems, Inc. manufactures the Foundation Lighting and Signs System to provide resistance to lateral loads and moment loads due to wind and other load conditions. The versatility and ease of construction of the CHANCE® Foundation Lighting and Signs System permits great flexibility in a number of applications. Typical uses for these products are foundations for equipment pads, foundation supports for signs, supports for light standards and decorative poles, and other eccentric load applications.

## PRODUCT BENEFITS

The Foundation Lighting and Signs System offers the following benefits:

- Fast installation.
- No vibration.
- Ease of installation in limited access areas.
- Minimum disturbance to site.
- No excavation required.
- All steel foundation.
- Immediate structure installation.
- Ready for immediate wiring.
- All weather installation.
- On-site load test capability.

This section describes the CHANCE® Foundation Lighting and Signs System products for overturning moment loads and lateral support that are typically maintained in stock to provide quick delivery to the project site. Table 10-1 and Figure 10-1 illustrate just a few of the Foundation Lighting and Signs products that are available in each of the product series. Our manufacturing facility is capable of rapidly fabricating products to suit the application.

**FOUNDATION LIGHTING AND SIGNS System Product Selection, Table 10-1**

DETAIL	CATALOG NO	PILE DIA	LENGTH	NOTES
A	T1120143	3-1/2"	5' - 0"	1. Manufacturer to have in effect industry recognized written quality control for all materials and manufacturing processes. 2. All material to be new, unused and mill traceable meeting specifications found on product drawing. 3. Additional lengths and configurations are available as standard catalog numbers.
B	T1120338	4"	4' - 8"	
C	C11232JG4VL	6-5/8"	5' - 0"	
D	C11242NG4VP	8-5/8"	5' - 0"	
E	T1120592	10-3/4"	5' - 0"	

LIGHTING AND SIGNS

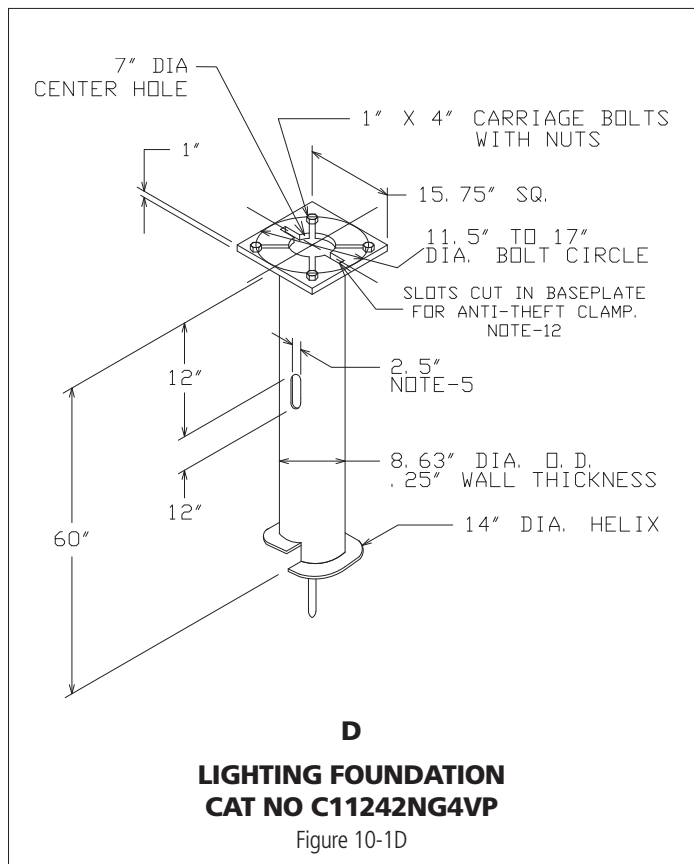
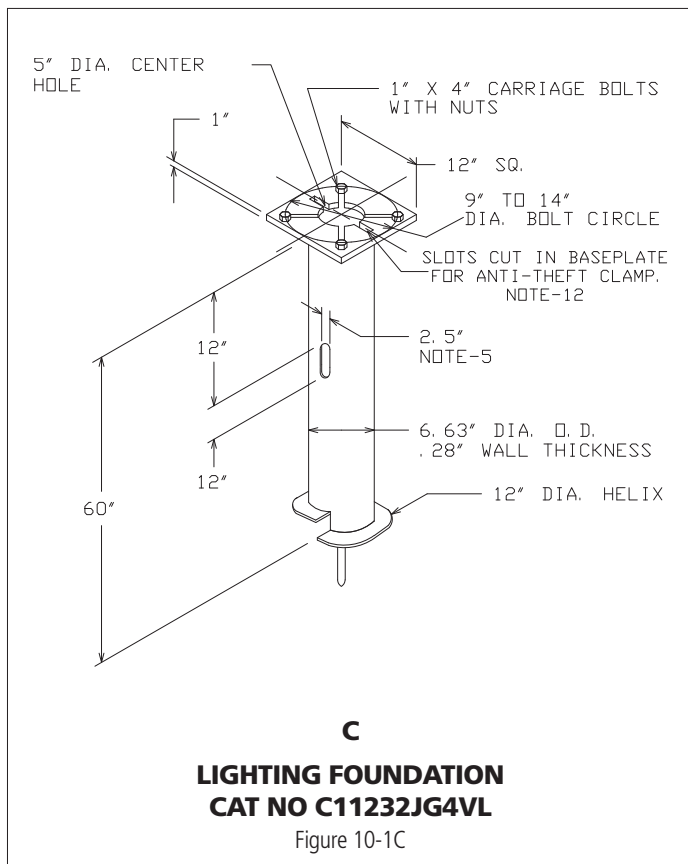
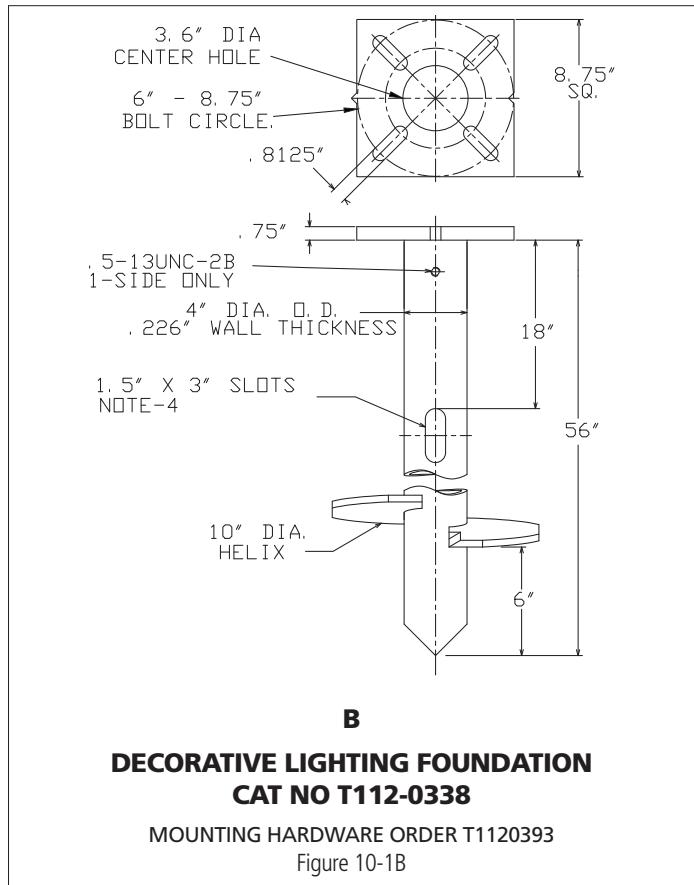
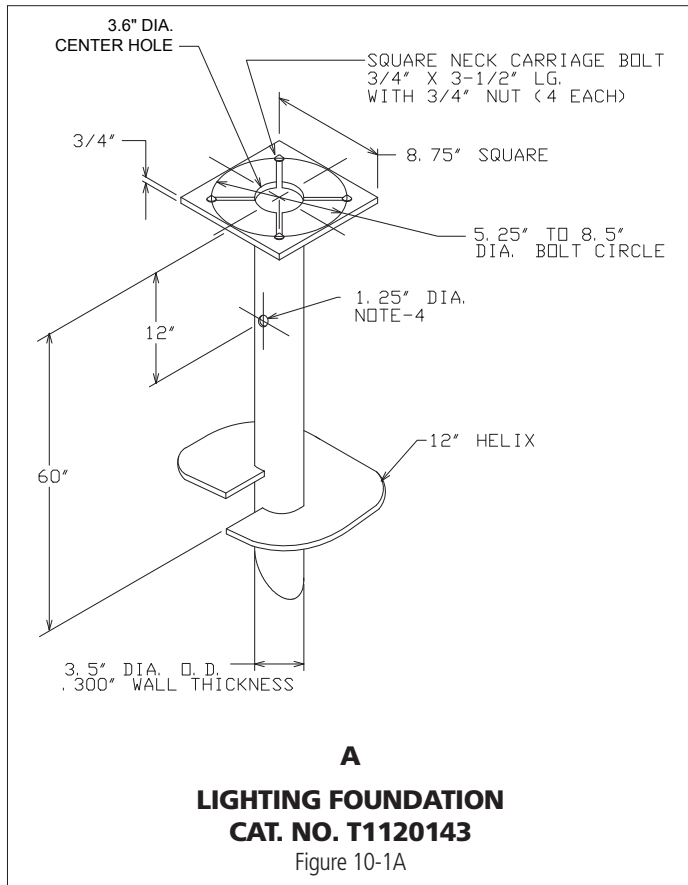

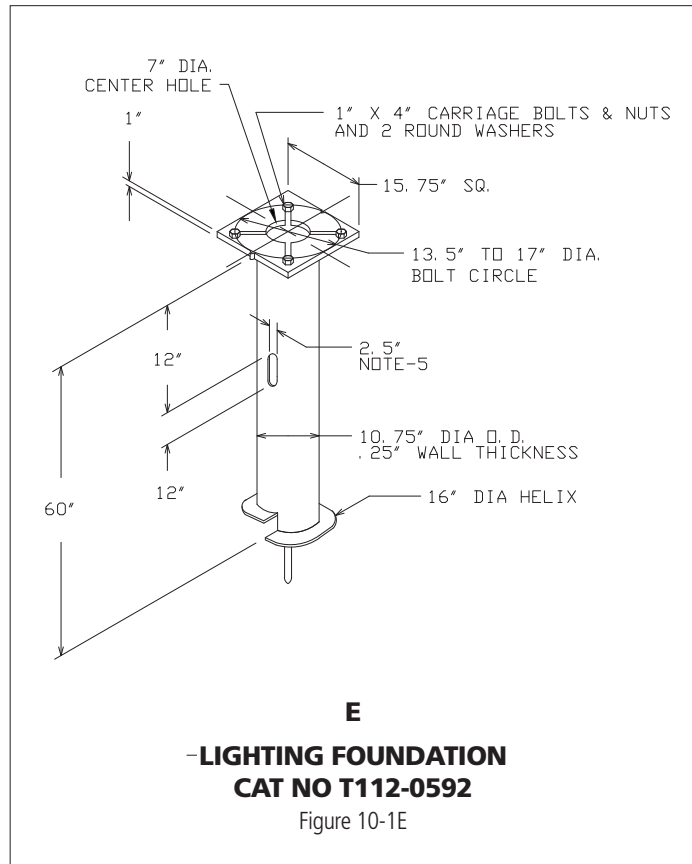
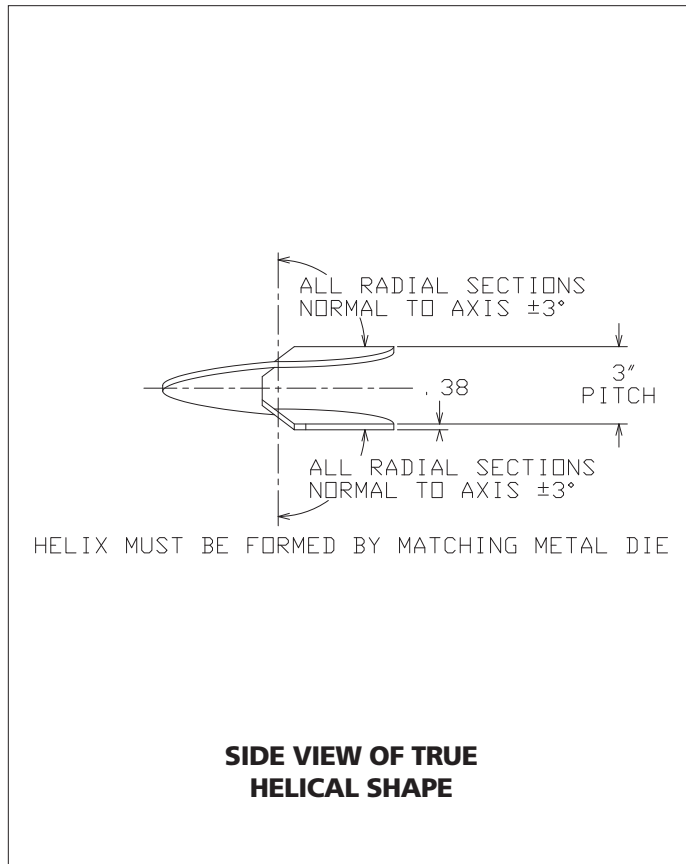

LIGHTING AND SIGNS

**RECOMMENDED FACTORS of SAFETY for DESIGN**

The variability of soil conditions that may exist at a project site, plus the varied nature of loading on structures and how these loads are transferred through foundation elements, requires the consulting engineer and/or dealer/installing contractor to use an appropriate Factor of Safety (FS) in design for use with the Chance® Foundation Lighting and Signs System. Generally this Factor of Safety is a minimum of 2:1 on all permanent loading conditions and a minimum of 1.5:1 for any temporary load situation. National and local building code regulations may require more stringent Factors of Safety on certain projects.

## DESIGN GUIDELINES

The Foundation Lighting and Signs System provides manufactured single helix fixed length products for use as foundations for varied applications such as light poles, signs and equipment supports. There are many applications for these tubular helical specialty products. Each application will require:

1. An evaluation of the soil strata and soil characteristics of that stratum in which the product will be installed.
2. A selection of the appropriate Foundation Lighting and Signs Product shaft diameter, shaft length, base plate size, bolt diameter and bolt circle diameter.
3. A determination of the ultimate bearing capacity and suitable Factor of Safety.

**NOTE:** The design should involve professional geotechnical and engineering input. Specific information involving the structures, soil characteristics and foundation conditions must be used for the final design.

The following preliminary design guide information is intended to assist dealers, installing contractors, and consulting engineers to select the appropriate CHANCE® Foundation Lighting and Signs Product to resist overturning moment and lateral load.

The Hubbell Power Systems, Inc. Pole Load Determination Data Sheet is provided on page 10-9. This can be used to gather and record the information required to determine the loads to be applied to a light pole foundation. The loads and given soil conditions are then used to determine the appropriate Foundation Lighting and Signs Product size required for the job. The SELECT-A BASE™ Lighting Base Program is an on-line program used for preliminary foundation selection. The program incorporates a database of CHANCE® Lighting Bases. The program inputs include loading conditions (wind, moment, and/or lateral), pole/pole arm details and soil data. The software is free and easy to use on-line at [www.abchance.com](http://www.abchance.com).

### INSTANT FOUNDATION® SYSTEM DESIGN STEPS

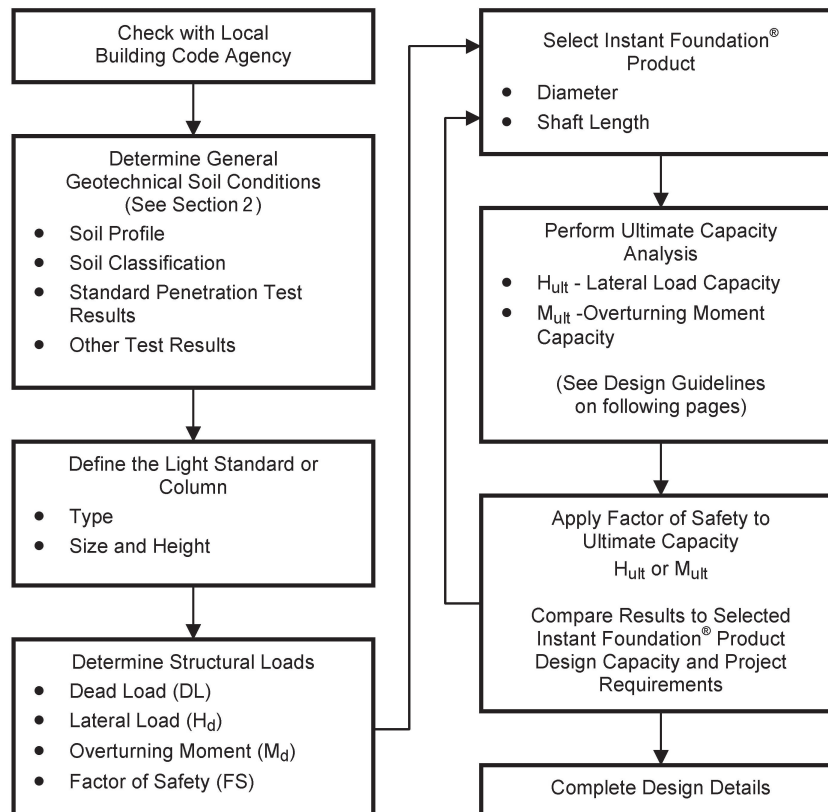

## LIGHT POLE STANDARDS PRODUCTS

CHANCE® Foundation Lighting and Signs® Products for light pole standards are designed to resist both the lateral forces and overturning moments from wind loads. Controlling design standards for wind loads can be determined either by consulting local or national building codes or conformance to standards set by the American Association of State Highway and Transportation Officials (AASHTO). These standards will provide the required design wind load based on geographic region and the factors associated with the shape and type of structure in order to determine the resulting wind pressure. This wind pressure is then applied to the effective projected area (EPA) of the light pole, arm and fixture. These lateral forces can be used to determine the resultant lateral force and overturning moment applied to the foundation as shown in Figure 10-4. The luminaire or fixture supplier may be consulted to determine the actual effective projected area for the specific light assembly.

Table 10-2 provides the suggested shaft diameter and installation requirements for various lateral load-overturning moment ranges. Table 10-3 provides the minimum recommended design life based on the structure type. This has been reproduced from AASHTO Specification, 4th Edition, 2001. The designer can make a site-specific analysis, or an analysis can be obtained by completing the Pole Load Determination Data Sheet on page 10-9 and submitting it to Hubbell Power Systems, Inc. to determine the most appropriate Instant Foundation® Product.

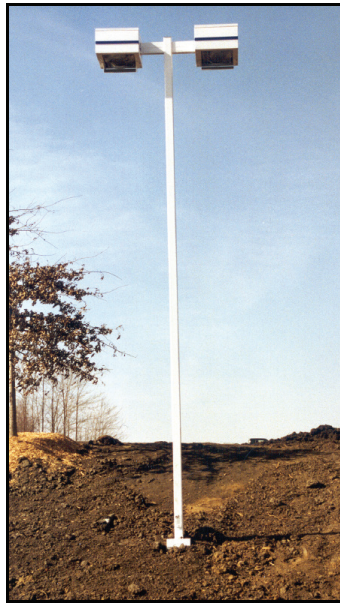

Installed Light Standard  
Figure 10-2



Foundation Lighting and Signs® Products are Easily Installed Using  
Common Construction Equipment.  
Figure 10-3

**CHANCE® Foundation Lighting and Signs® System for Light Standards, Table 10-2**

DESIGN LATERAL LOAD <sup>2</sup>	DESIGN OVERTURNING MOMENT <sup>2</sup>	RECOMMENDED HELICAL FOUNDATION <sup>2</sup>	PRODUCT PART NUMBER
150 – 500 lb.	≤ 2,800 ft-lb.	3.5" Dia x 5' Long	T1120143
150 – 500 lb.	≤ 3,500 ft-lb.	4" Dia x 4'-8" Long	T1120338
500 – 1,000 lb.	≤ 10,500 ft-lb.	6-5/8" Dia x 5' Long	C11232JG4VL
1,000 – 1,200 lb.	≤ 21,000 ft-lb.	8-5/8" Dia x 5' Long	C11242NG4VP
1,200 – 1,500 lb.	≤ 37,000 ft-lb.	10-3/4" Dia x 5' Long	T1120592

Notes:

1. The above lateral loads and overturning moments are mechanical ratings of the indicated foundation. Project soil conditions must be evaluated during preliminary design.
2. These design loads are based on allowable bending in the pipe shaft with cableway widths of 1.25" in 3.5" dia, 1.5" in 4" dia and 2.5" in all other foundations.

LIGHTING AND SIGNS

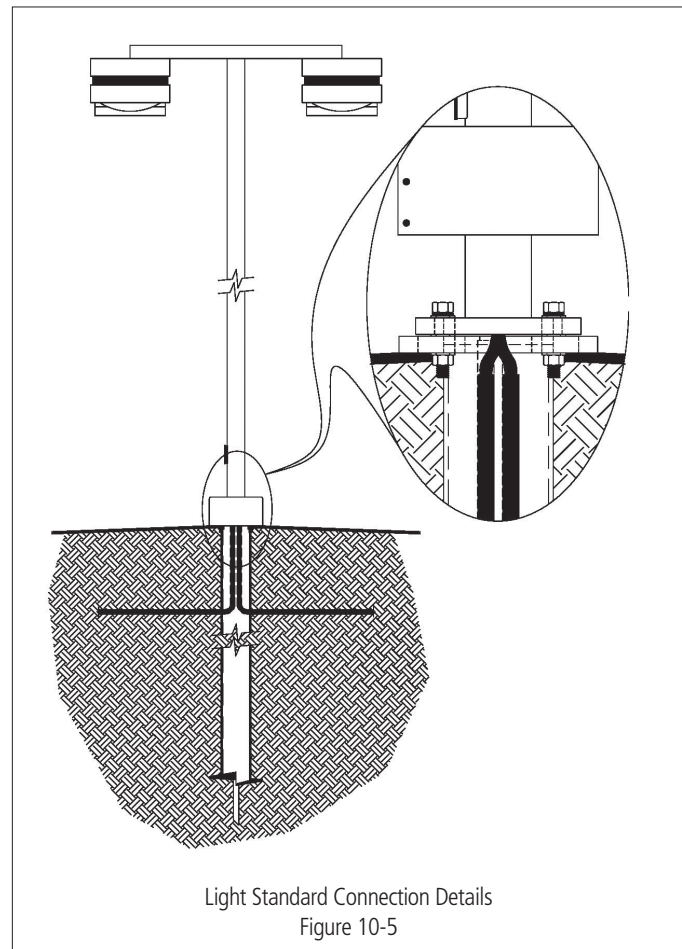
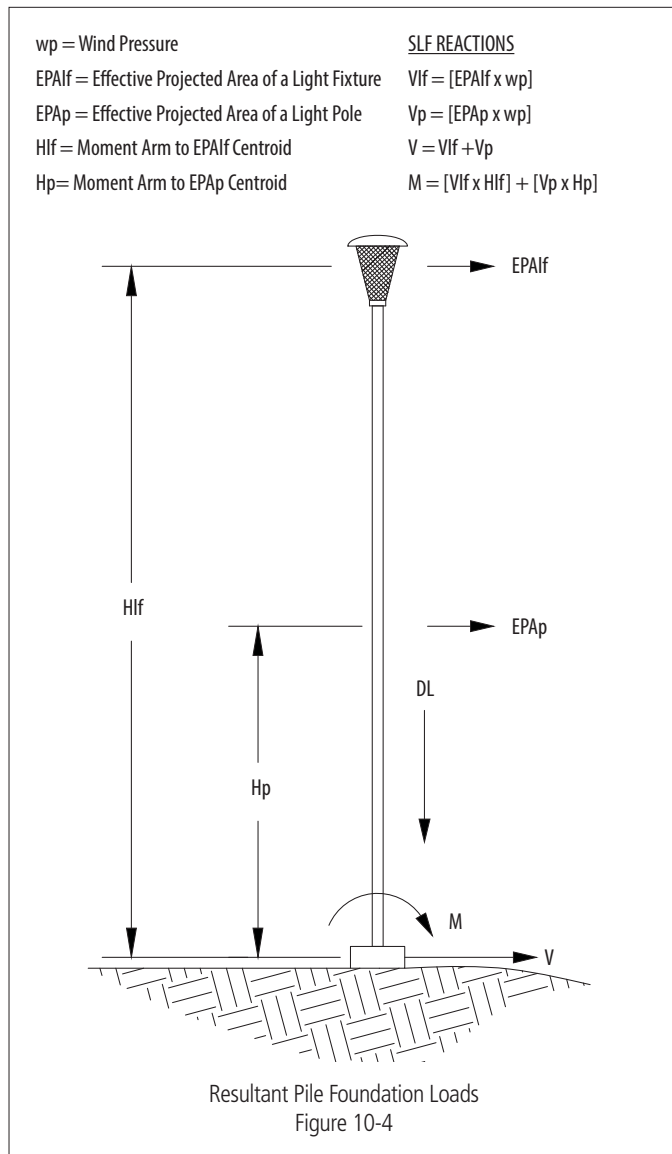



### Recommended Minimum Design Life, Table 10-3

DESIGN LIFE	STRUCTURE TYPE
50 Years	<ul style="list-style-type: none"> <li>• Luminaire support structures exceeding 15m (49.2 ft) in height.</li> <li>• Overhead sign structures.</li> </ul>
25 Years	<ul style="list-style-type: none"> <li>• Luminaire support structures less than 15m (49.2 ft) in height.</li> <li>• Traffic signal structures.</li> </ul>
10 Years	<ul style="list-style-type: none"> <li>• Roadside sign structures.</li> </ul>

(Reproduced from AASHTO Specification, 4th Edition, 2001)

### LATERALLY LOADED FOUNDATIONS

Certain projects require a rapidly installed foundation that must resist lateral loads. Examples of these projects include:

- Equipment platforms for communication towers or mechanical systems.
- Seaside structures subjected to wave action.
- Temporary classroom/mobile building foundations.
- Solar Panels

Each project must be evaluated and designed and should include geotechnical and professional engineering input. Hubbell Power Systems, Inc. offers a "Preliminary Design Service" for evaluating the feasibility of using Foundation Lighting and Signs® Products on such specific projects.

### FOUNDATION LIGHTING AND SIGNS® SYSTEM SPECIFICATIONS

The Specification at the end of this section provides a typical specification for the CHANCE® Foundation Lighting and Signs® System.

1. American Association of State Highway and Transportation Officials (AASHTO) Specification, 4th Edition, 2001.
2. Uniform Building Code, Volume 2 - Division 3, 1997.

### POLE LOAD DETERMINATION DATA SHEET

Luminaire mounting height:		<input type="checkbox"/> m	<input type="checkbox"/> ft
Height of pole:		<input type="checkbox"/> m	<input type="checkbox"/> ft
Outside diameter of pole top:		<input type="checkbox"/> cm	<input type="checkbox"/> in
Outside diameter of pole bottom:		<input type="checkbox"/> cm	<input type="checkbox"/> in
Arm length:		<input type="checkbox"/> m	<input type="checkbox"/> ft
Arm tip outside diameter:		<input type="checkbox"/> cm	<input type="checkbox"/> in
Arm bottom outside diameter:		<input type="checkbox"/> cm	<input type="checkbox"/> in
Luminaire weight:		<input type="checkbox"/> kg	<input type="checkbox"/> lb
Luminaire EPA (projected area x C <sub>d</sub> ):		<input type="checkbox"/> m <sup>2</sup>	<input type="checkbox"/> ft <sup>2</sup>
Basic wind speed:		<input type="checkbox"/> kph	<input type="checkbox"/> mph
Minimum design life (Default design life is 25 yrs. See Table 10-3):		<input type="checkbox"/> 10 <input type="checkbox"/> 25 <input type="checkbox"/> 50 yrs	
Number of arms:			
Number of luminaires:			
Pole shape:	<input type="checkbox"/> Cylinder <input type="checkbox"/> Flat <input type="checkbox"/> Hexdecagonal (16 sides) <input type="checkbox"/> Dodecagonal (12 sides) <input type="checkbox"/> Octagonal (8 sides) <input type="checkbox"/> Square (4 sides) <input type="checkbox"/> Diamond		
Arm shape:	<input type="checkbox"/> Cylinder <input type="checkbox"/> Flat <input type="checkbox"/> Hexdecagonal (16 sides) <input type="checkbox"/> Dodecagonal (12 sides) <input type="checkbox"/> Octagonal (8 sides) <input type="checkbox"/> Square (4 sides) <input type="checkbox"/> Diamond		
Is this pole/foundation in Alaska?		<input type="checkbox"/> Yes	<input type="checkbox"/> No
Required foundation bolt diameter:		<input type="checkbox"/> cm	<input type="checkbox"/> in
Required foundation bolt circle diameter:		<input type="checkbox"/> cm	<input type="checkbox"/> in
Site Soil Data (if available):			

LIGHTING AND SIGNS

## SPECIFICATION

### CHANCE® Foundation Lighting and Signs® System

- 3-1/2" Dia x 0.300" Wall
- 6-5/8" Dia x 0.280 Wall
- 10-3/4" Dia x 0.250" Wall
- 4" Dia x 0.226" Wall
- 8-5/8" Dia x 0.250" Wall

The usual application for this foundation is where loads are moderate and the project requires greater column stiffness than is possible with the typical square shaft helical pile. Examples of applications are: Light Standards, Curbside Business Sign Support, Electrical/Mechanical Equipment Pad Support, Cantilevered Loads, etc.

### PART 1 – GENERAL

#### 1.1 SCOPE OF WORK

This work consists of furnishing labor, tools, equipment and materials associated with the preparation and installation of the CHANCE® Foundation Lighting and Signs® System for structural foundation support according to the specifications contained herein. The work includes, but is not limited to, the following:

1. Diligent investigation of the possible existence and location of underground utilities situated at or near the area of work;
2. Excavation and preparation of foundation soil to grade for foundation installation;
3. Mounting of the hydraulic gear motor on a backhoe unit or similar auxiliary powered equipment, and the installation of the Foundation Lighting and Signs® Product to the required torque resistance at the required depth (if torque resistance measurement is required).
4. Removal of the hydraulic gear motor.
5. Conducting an optional Field Load Test on one or more Foundation Lighting and Signs® Products.
6. Clean Up.

#### 1.2 REFERENCES

1. Building Officials and Code Administrators International, Inc. (BOCA) Basic National Building Code.
2. American Association of State Highway and Transportation Officials (AASHTO) Standard Specifications for Structural Supports for Highway Signs, Luminaires and Traffic Signals.

#### 1.3 DELIVERY, STORAGE AND HANDLING

All foundation products shall be handled and transported carefully to prevent any deformation or damage. Care should be taken to prevent the accumulation of dirt, mud or other foreign matter on the steel materials. Such accumulation shall be completely removed prior to installation.

### PART 2 - MATERIAL

#### 2.1 HYDRAULIC GEAR MOTOR

The torque rating of the hydraulic gear motor used to install the Foundation Lighting and Signs® Product shall be adequate to install the required foundation. It is suggested that the torque rating be 25 percent higher than the planned installation torque. Depending upon the soil conditions and pile configuration, different hydraulic gear motors may be required.

## 2.2 3-1/2" and 4" DIAMETER HELICAL FOUNDATION LIGHTING AND SIGNS® SERIES

### 2.2.1 Foundation Shaft Section

The shaft section consists of a tubular hot rolled steel pile section 3-1/2" in diameter with a 0.300" wall thickness, or 4" diameter with a wall thickness of 0.226" conforming to ASTM A-53, A-252 and A-500. The length of the foundation shall be as specified: 4', 4'-8", 5', etc. The lead end of the 3.5" and 4" foundations shall have a single or double bevel cut to aid in starting the foundation installation. Welded to the shaft shall be one ASTM A-635 steel helical plate with a thickness of 3/8" and a 3" pitch.

### 2.2.2 Foundation System Base Mounting Plates

Foundation base plates may be round or square, of various sizes in plan view and may vary in thickness from 1/2" to 1-1/2" depending on job requirements.

## 2.3 6-5/8", 8-5/8" and 10-3/4" DIAMETER HELICAL FOUNDATION LIGHTING AND SIGNS® SERIES

### 2.3.1 Foundation Shaft Section

The shaft section consists of 6" diameter (6-5/8" outside diameter with 0.280" wall), 8" diameter (8-5/8" outside diameter with 0.250" wall) or 10" (10-3/4" outside diameter with 0.250" wall) steel pipe conforming to ASTM A-53, A-252 or A-500. The length of the foundation may be 4', 5', 7', 8' or 10' long as required by the application. The pile section shall have two wire access slots located 180° from each other. The integral foundation cap plate shall have an alignment notch located directly above one of the wire access slots. Welded to the lead end of the foundation shaft shall be a steel helical plate with a 3" pitch. To aid in starting the pile, a 1-1/4" diameter steel rod shall extend beyond the center of the helix to provide a pilot.

### 2.3.2 Foundation System Base Mounting Plates

Foundation base plates may be round or square, of various sizes in plan view and may vary in thickness from 3/4" to 1-1/2" depending on job requirements.

## 2.4 WELDMENTS

All welded connections shall conform to the requirements of the American Welding Society Structural Welding Code, AWS D1.1 and applicable revisions.

## **PART 3 - EXECUTION**

The following is intended to provide the controlling specification for the major steps undertaken in the installation of the CHANCE® FOUNDATION LIGHTING AND SIGNS® Systems. Variations in the installation procedure may occur depending on the application and the structural support required.

**WARNING! THOROUGHLY INVESTIGATE THE POSSIBLE EXISTENCE AND LOCATION OF ALL UNDERGROUND UTILITIES SITUATED AT OR NEAR THE AREA OF WORK BEFORE PROCEEDING. SERIOUS INJURY MAY RESULT FROM FAILURE TO LOCATE ALL UNDERGROUND UTILITIES.**

### 3.1 PREPARATION

The soil shall be excavated to the proper grade for placement of the CHANCE® Foundation Lighting and Signs® Product. Stakes should be set at each foundation location prior to commencement of work. The foundation layout and staking should be under the supervision of the responsible structural engineer and be accomplished using fully qualified and trained technicians familiar with foundation layout.

### 3.2 INSTALLATION OF THE FOUNDATION LIGHTING AND SIGNS® PRODUCT

The hydraulic gear motor shall be installed on a backhoe or other suitable pile installation unit. Mount the Foundation Lighting and Signs® Product to the hydraulic gear motor via the appropriate kelly bar adapter and installing tool using two structural grade bolts and nuts. The foundation is positioned vertically over a marked pile location and driven into the soil by means of the hydraulic gear motor. Rotary

installation continues until the required design torque is achieved at or below the predetermined depth. The baseplate is typically installed to grade or slightly above to allow clearance for bolt mounting of the pole base. It is important that the installation torque remain at or above the predetermined value during this process. Details of the installation shall be provided to the supervising engineer for review.

### 3.3 DOCUMENTATION

When required, the dealer/installing contractor shall monitor the torque applied to the foundation during installation. It is recommended that the installation torque be recorded at one-foot intervals throughout the installation. The installation torque may be measured with a calibrated torque indicator. At the conclusion of the installation, a copy of the foundation installation record shall be provided to the engineer for review.

### 3.4 LOAD TEST (Optional)

A detailed description on the requirements and procedures for conducting a Load Test may be found in Appendix B (LOAD TESTS). The results of the Field Load Test provide guidance for determining the ultimate and allowable foundation loads.

**Load testing should be conducted under the supervision of the responsible engineer.**

Depending on the project specifications, a Working Load Test may be required. Normally, the first installed foundation is selected for this test; however, some specifications require ultimate loading of the foundation. If an Ultimate Load Test is required, a test foundation must be installed in an alternate location on the site in addition to the pile locations marked. After the Ultimate Load Test is completed, the test foundation may be removed from the soil and used on the project, provided it is not damaged.

### 3.5 CLEAN UP

Upon completion of the installation of the CHANCE® Foundation Lighting and Signs® Product, all equipment shall be removed from the site. Any disturbed soils in the area of the foundation shall be restored to the dimensions and condition specified by the engineer.

**END OF SPECIFICATION**